

Industrial Valves

<http://www.industriearmaturen.de>

Safety shut-off devices for industrial plants

UWE KRABBE

Kühme Armaturen GmbH, 44894 Bochum/Germany
Phone: +49 234 29802-41, krabbe@kuehme.de

published in Industrial Valves, International Edition of Industriearmaturen 2010/2011

Vulkan-Verlag GmbH, Essen, Germany

Contact: W. Mönning, Tel. +49 201 82002-25, w.moening@vulkan-verlag.de



→ Your satisfaction is our ultimate goal!



OUR MISSION

The most valuable asset for us is our good reputation. Since 1967, the name KÜHME has stood internationally for the quick, safe and reliable shutting off of combustible media, outstanding quality and fair cooperation with both customers and employees.

It is therefore our highest aim to retain and increase your degree of satisfaction with our products. We are an owner-managed, financially independent private company that manufactures in Germany. We maintain and promote the commitment and the knowledge of our team, we invest in our location, in research and development and in our service – as we also wish to impress you with a sustainable and in every way first-class range of goods and services, both now and in future.

safe and reliable



Safety shut-off devices for industrial plants

Uwe Krabbe

The following article describes safety shut-off devices that must be used in the industrial sectors of energy generation, chemicals, petrochemicals, metallurgical plants, water management, tank facilities and other industries where plants are subject to high safety requirements. It is, of course, important here to use the „right“ valve for the relevant application. The article aims to provide an overview of the various possible applications for safety shut-off devices.

Selection, design, manufacturing and use of valves are based on legal provisions and/or technical regulations:

- Pressure Equipment Directive (PED) 97/23/EC
- ATEX 94/9/EC (ATmosphères Explosibles from the French title of 94/9/EC)
- AD datasheets (AD = German Working Group for Pressure Vessels)
- DIN, EN and ISO standards
- VDE regulations (VDE = German Association for Electrical, Electronic & Information Technologies)
- Technical Instructions on Air Quality Control (TA-Luft-2002)
- Safety Integrated Level (SIL) according IEC EN 61508

and others.

Over the past few years, these requirements for safety shut-off devices have increased significantly in relation to functional safety, service life, maintenance and, last but not least, environmental protection.

Standard valves

Safety shut-off devices in steam boiler firing systems in accordance with EN 12952-8 and EN 12953-7

For safety reasons, oil and gas firing systems are fitted with two safety shut-off devices arranged behind one an-

other, directly upstream of each burner or burner assembly. It is also possible in the case of gas firing systems to fit the double block with intermediate venting and/or a tightness monitoring device (**Figure 1**).

The reliability of these safety shut-off devices is proven by means of a type test, in accordance with PED 97/23/EC based on EN 13611/EN 161/DIN 3394 Part 1 Group A for gas valves and in accordance with DIN EN ISO 23553-1 for oil valves. During these type tests, up to 500,000 operating cy-

cles are run under operating conditions, depending on the nominal diameter, in order to ensure reliable continuous functioning.

Furthermore, this test also includes testing of the „internal“ and „external“ tightness, as well as the closing time, which must be *less than 1 second* over the entire test period.

A successful test result is documented with a Product Identification No. (PIN-No.) for gas and oil valves, for gas valves also a registration by the DVGW



Fig. 1: Safety shut-off valve-combination

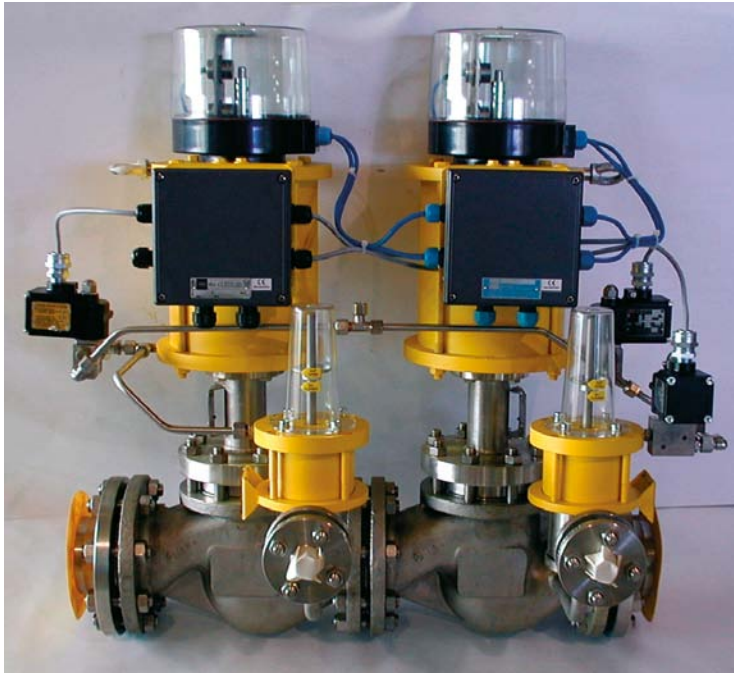

Fig. 2: Safety shut-off device for gas turbines

(German Technical and Scientific Association for Gas and Water) with a DVGW-Register-No. is possible.

The safety shut-off devices as a single valve or as a valve-combination are supplied in the nominal diameters of DN 15 to 300 and are assembled according to a modular system for the trim element, stem seal and actuator.

The standard versions are available complete with 3/2-way solenoid valve, quick-acting vent valve, „open/closed“ limit switches and limit protective cover.

The standard materials are:

- Valve body in forged steel P250GH or cast steel GP240GH
- Valve cone and internal parts made of stainless steel or chromated steel
- Valve cone seal made of NBR, FKM or PTFE glass
- Special materials on request
- Valve stem seal: Stainless steel bellows or automatic seal kit made of PTFE graphite, with a downstream lip seal and test connection. This versions are certified according to TA Luft 2002.

The design is carried out according to operating data and customer requirements.

Gas turbine quick-closing valves

The use of gas turbines has increased considerably in recent years. The combustion system for gas turbines is also subject to the same technical regulations as steam boiler systems in accordance with EN 12952-8 and EN 12953-7, whereby lines carrying fuel are to be fitted with safety shut-off devices. In cooperation with leading gas

turbine manufacturers, the gas turbine quick closing valves were modified on the basis of the standard series in line with the higher requirements (**Figure 2**). Similarly to the standard series, type tests were carried out here too.

Quick-closing shut-off butterfly flap valves as a safety shut-off device for gaseous fuels

For gases with a low net calorific value e. g. blast furnace gas and coke oven gas with low operating pressures, shut-off devices with large nominal diameters are generally required. As a quick-closing valve, so-called butterfly flap valves with nominal diameters of DN 250 to 3,000 (**Figure 3**) have proven successful.

The butterfly flap valve is used in systems with high tightness requirements, where safety and reliability are top priority. This special system of a plate/seat seal, available as a single or double seat seal (double seat design can be used in systems with a gas-pressure up to 200 mbar according to EN 12952-8), enables a high level of tightness and extremely short closing times. Actuation is carried out with a pneumatic piston actuator, and the closing action is carried out via closing springs fitted to the outside of the actuator. For the nominal diameters up to DN 1600 for single seat design and up to DN 1300



Fig. 3: Safety shut-off butterfly flap valve

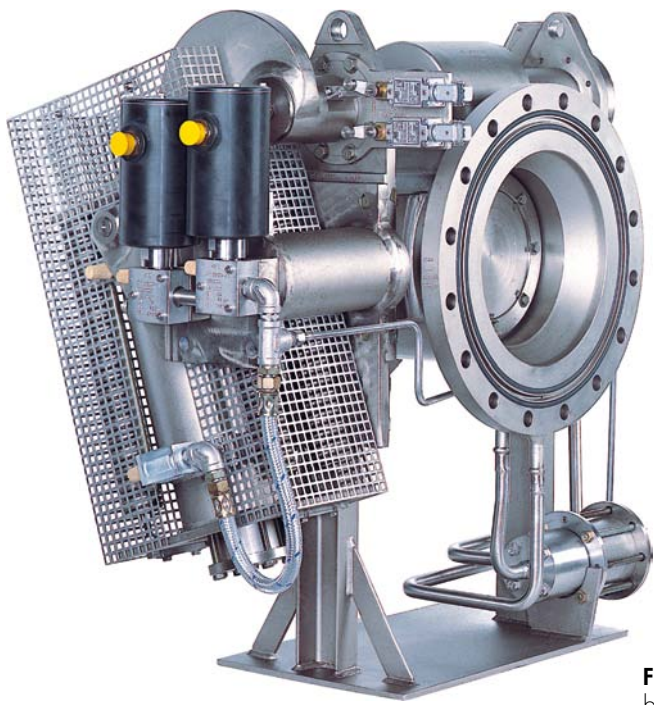

Fig. 4: Containment shut-off butterfly flap valve

tomers and operators. A further development of these butterfly flap valves is used as a containment shut-off valve in the HVAC (Heating, Ventilation and Air Conditioning) system of nuclear power plants around the world (**Figure 4**).

Tailor-made safety shut-off devices

This section describes safety shut-off devices manufactured to meet special requirements, such as actuating function, closing time, control, chemical resistance, pressure, etc.

Pipe burst safety valve-combination

In a part of a chemical plant a thermal oil system with heat exchanger was installed. The thermal oil system has a pressure from 6 bar (g) and a temperature from 320 °C. The heat exchanger has a pressure from 100 bar (g) and a temperature from 300 °C. If a pipe burst is happen at the heat exchanger the high pressure comes into the thermal

for double seat design the flap valves are type tested and certified according PED 97/23/EC and EN 161.

This sophisticated design is the result of decades of operating experience, as well as close cooperation with cus-

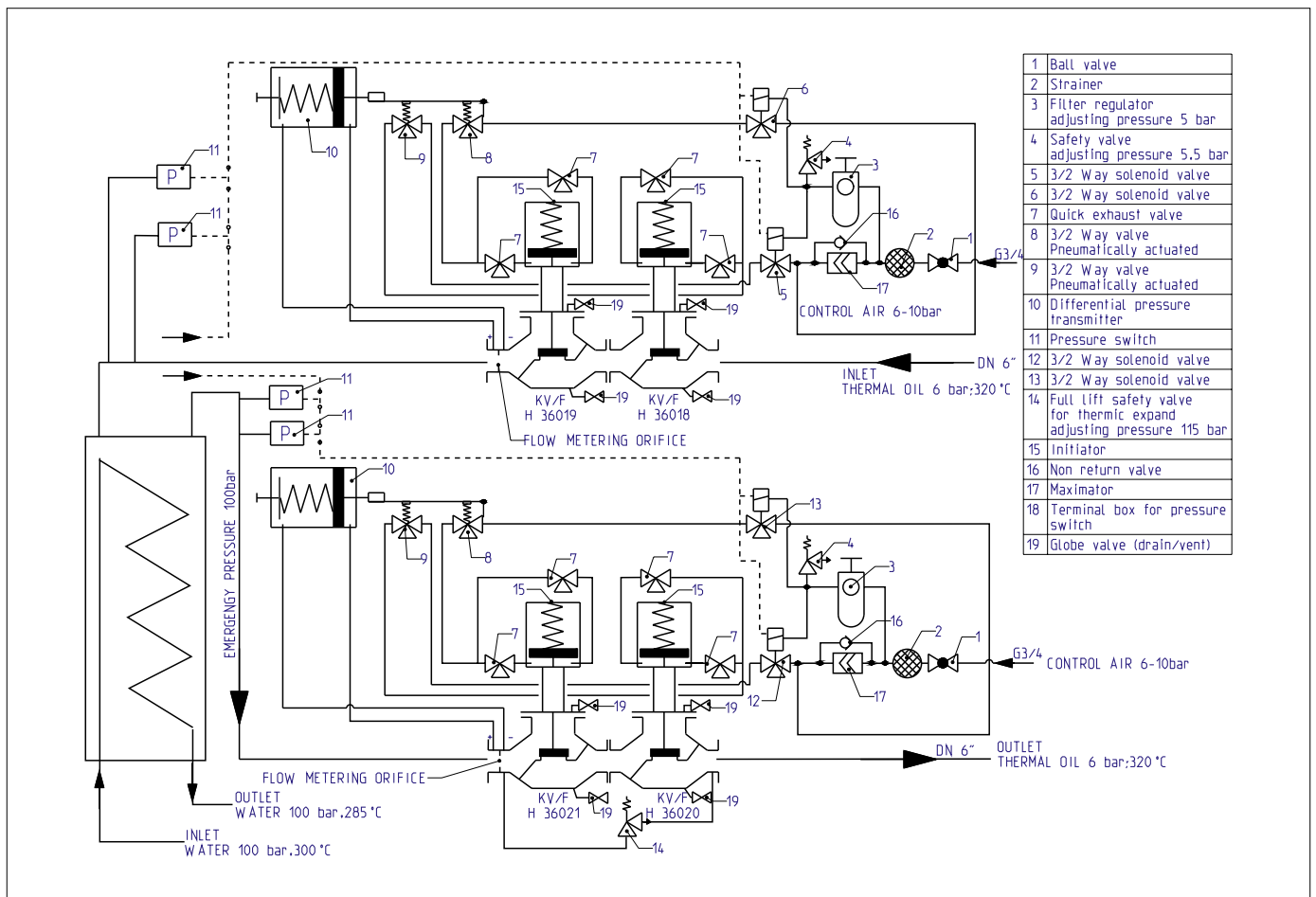

Fig. 5: Flow diagram thermal oil heating



Fig. 6: Safety shut-off devices for thermal oil

oil system. To prevent this a safety shut-off device must be installed at the inlet and outlet of the heat exchanger (**Figures 5 and 6**).

One task is to achieve particularly short closing times in order to prevent or limit the discharge of steam with high pres-

sure in the event of a burst pipe in the thermal oil system. Another task is that the setting of for quick closing comes from a control unit which is divergent-redundancy. In this case we have for the electric side pressure switches/pressure gauges with electric contacts and for the hydraulically/mechanically side an

integrated orifice and a trip pilot valve. When designing such a safety device, the following factors must be taken into consideration:

- Type of medium
- Level of operating pressure
- Medium temperature
- Selection and resistance of sealing materials
- Number of switching cycles
- Calculation of actuating forces
- Type of control (e.g. pneumatic)
- Size of the control cross-sections
- Pressure of the control medium

A critical point – in the case of fluid media – is the significance of the fluid column pressure surge (fluid hammer). Depending on the upstream pipe length, in the case of extremely short actuating times, pressure peaks may occur, which are many times higher than the operating pressure and which affect the valve and the pipe system. This should be taken into consideration when selecting the nominal pressure level and designing the internal valve components. It is also important that, not only to offer such a safety shut-off device, but also to test it under operating conditions.



Fig. 7: Safety shut-off Valve, electro hydraulically controlled

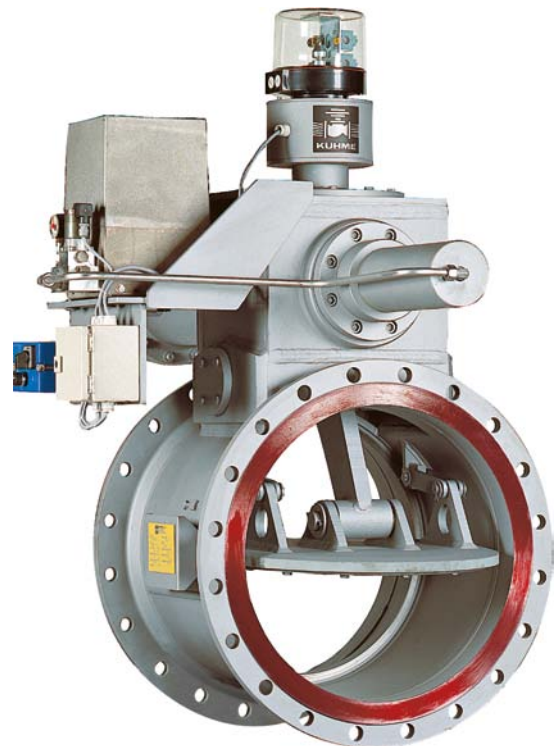

Fig. 8: Safety shut-off butterfly flap valve, electro hydraulically controlled



Fig. 9: Valve station for gas firing

Safety shut-off devices with an electro-hydraulic actuator

An alternative means of actuation to the otherwise used electro-pneumatic actuations is electro-hydraulic actuation. In this actuator system, the quick-closing valve or the quick-closing flap valve is fitted with a hydraulic piston cylinder and a hydraulic unit (**Figures 7 and 8**). The auxiliary energy required for actuation is hydraulic oil stored in the housing of the hydraulic unit, which also serves as an oil reservoir.

The mounted hydraulic unit comprises the following components:

- Housing also functioning as an oil reservoir with oil filler neck
- Built-in hydraulic pump
- Mounted pressure retention valve, actuating speed regulator and electrical solenoid valve for cylinder control
- Electrical control box with terminal strip for supply and control voltage
- Return spring installed in a sealed spring housing

The use of such an actuator is best suited to anywhere where it is difficult to install a compressed air supply.

The quick-closing valve or quick-closing butterfly flap valve corresponds in terms of its design such as the sealing system, actuating forces and materials, to the

type tested safety shut-off devices, so as to ensure functionality and reliability.

Valve stations for gas and oil firing system

Ready-to-connect valve stations, planned and designed in line with the technical regulations, operator guidelines and installation criteria. These valve stations are an easy-to-install option, incorporating the necessary equipment into the fuel line. For this, the manual shut-off valves, strainers and safety shut-off devices, for example, as well as the attachment parts and accessories, are mounted on a sectional steel frame, connected to the pipework and, if necessary, electrically wired. The station is prepared so that it is ready for connection and can be installed in the line, connected to the compressed air auxiliary energy, and electrically wired, and its functionality and tightness has been tested in the factory (**Figure 9**).

On request, additional valves can be incorporated into the station for control, measurement and monitoring purposes.

Conclusion

This report shows only a small part of safety shut-off device applications. The requirements for safety shut-off devices becomes more comprehensive every year, but this is a challenge to reach.

The Author



Uwe Krabbe

Kühme Armaturen GmbH
44894 Bochum/Germany
Phone: +49 234 29802-41
krabbe@kuehme.de

The Company

KÜHME is among the world's leading manufacturers of safety shut-off valves, high-performance special valves and single plate gate valves (conduit gate valves). First class quality and innovation has been the company's motto ever since its founding in 1967 and reflects its philosophy of dynamic leadership. Its valves are known for their safety, high reliability and long service life. The quality system is certified according to DIN EN ISO 9001-2008 and Pressure Equipment Directive (PED) 97/23/EC. KÜHME's corporate philosophy is to make available to the market new and better valve designs with special emphasis on safety, quality, long service life and ease of maintenance.

KÜHME valves are used in thermal power plants (TPP), nuclear power plants (NPP), steel mills, oil refineries, chemical plants, industrial plants, gas compressor stations, gas- and oil-metering station, underground gas-storage facilities, gas treatment plants, high and medium pressure supply lines for gas and oil, low pressure distribution networks.

www.kuehme.de



safe and reliable



KÜHME Armaturen GmbH

Am Vorort 14

44894 Bochum

Germany

Telephone: +49 (0) 234 - 29802 - 0

Fax: +49 (0) 234 - 29802 - 10

E-mail: info@kuehme.de

Internet: www.kuehme.de